

THERMAL LINEAR ACTUATORS

PAS linear actuators are designed with integrators in mind. The linear actuators offer multiple mounting configurations to make integration into any automated system effortless. State-of-the-art 3D CAD files for all PAS actuators are available in multiple file types to allow designers the ability to simply drop the actuator into their current machine design. Actuators are available with multiple forces and strokes to fit your specific automation needs.

OPERATIONAL AND DESIGN FEATURES

- **Standard PAS columns available**
- **Multiple configurations available**
- **1/4 ton to 2 ton actuators available**
- **Modular Thermal power supplies up to 12 zones**
- **Optional system controller with large operator interface**
- **Standard tooling bolt patterns work with any model PAS machine**
- **Multiple mounting access points on any axis or plane**
- **Hydraulic dampener**



SPECIFICATIONS

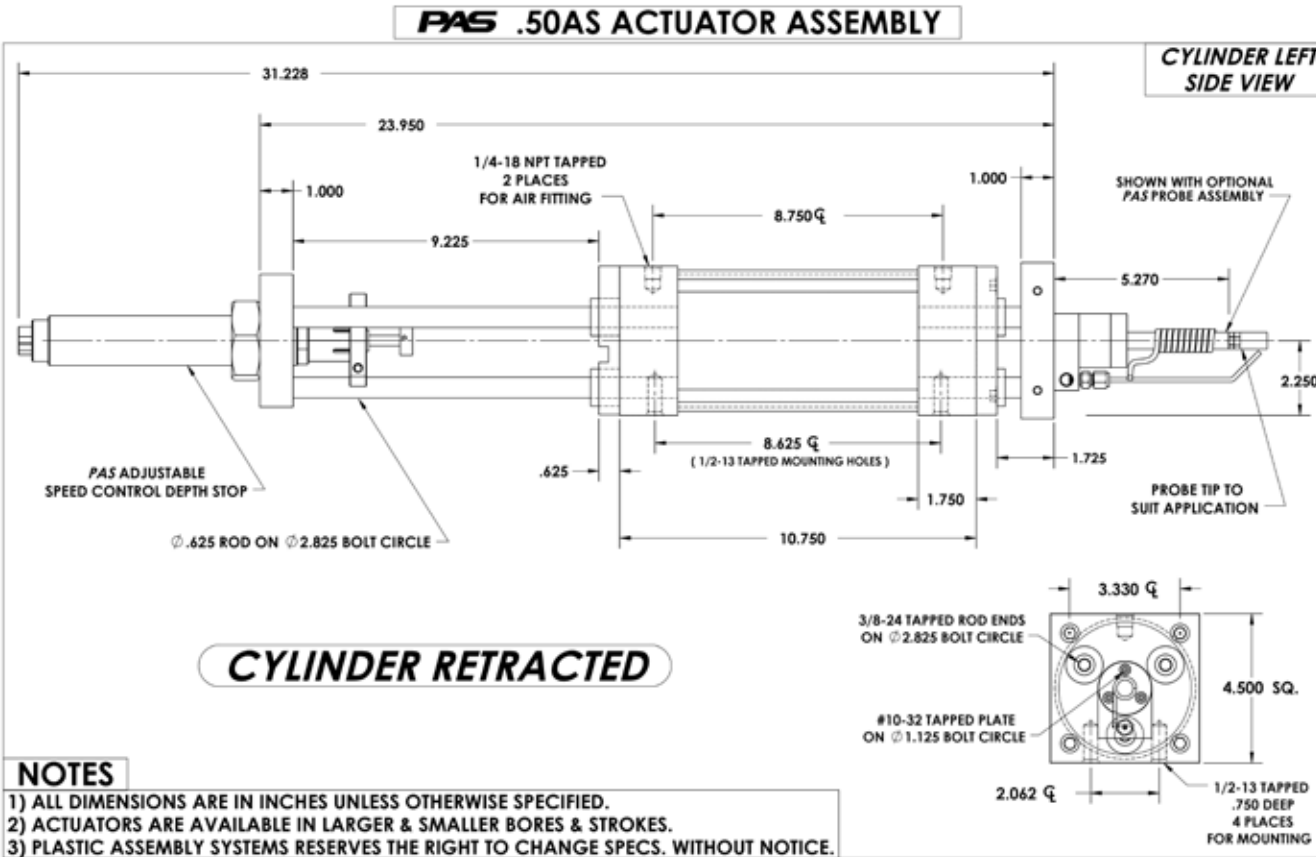
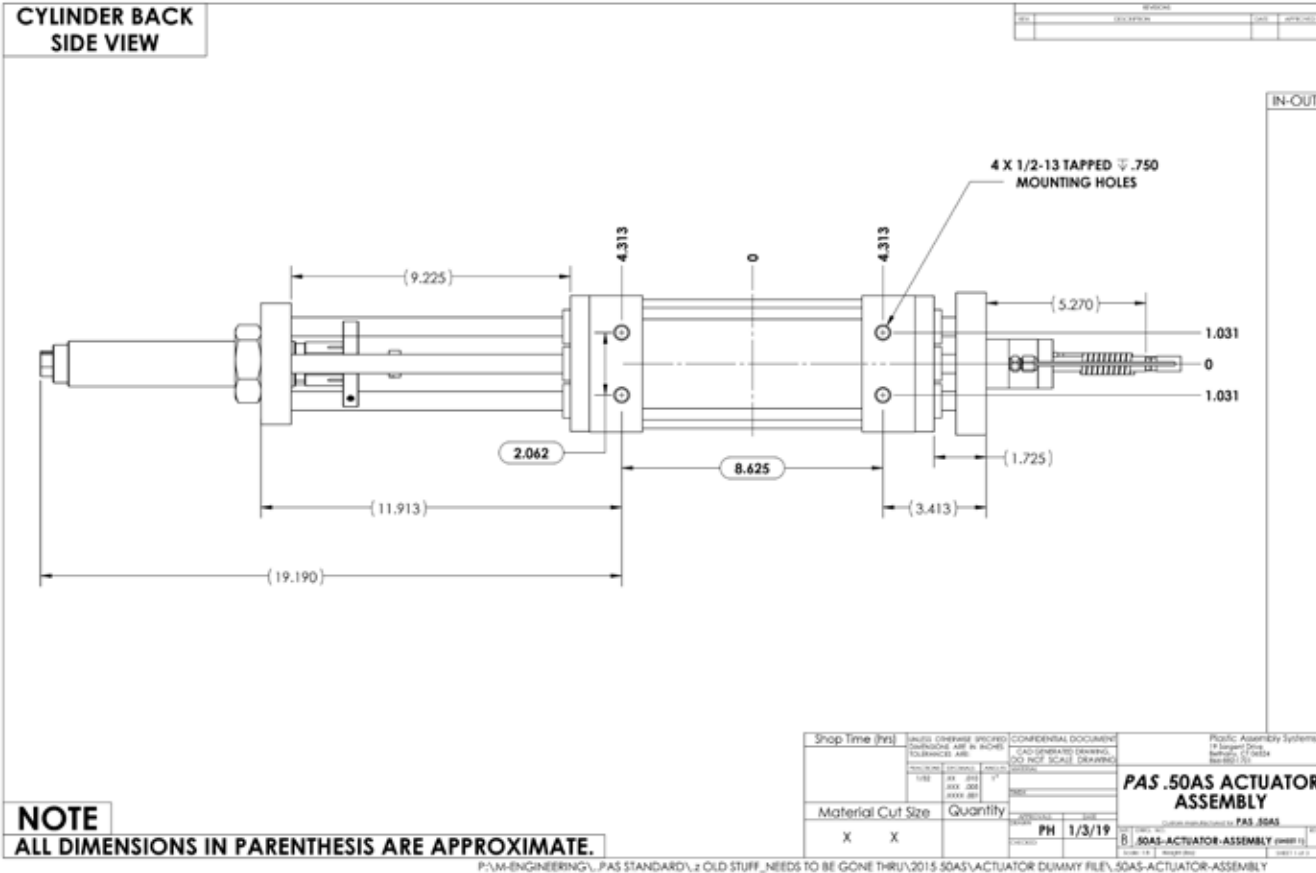

SPECIFICATIONS

PAS .50AS ACTUATOR ASSEMBLY

