

MODEL .25 ACTUATOR SYSTEM

The PAS Model .25 Actuator system is a low cost precision heatstaking machine designed for production runs of small to medium sized parts.

Heatstaking, thermal insertion, swaging, de-gating, date-coding, sealing, and serializing all make use of direct contact heated tools. Also precisely controlled time, temperature, and pressure are used to reform plastic studs, walls, protrusions, and or to embed metal components into plastic. This offers the ability to perform multiple operations on several planes simultaneously. Cycle times are relatively quick, and productivity can be increase through the assembly of multiple products simultaneously. After the thermal process, cosmetics are so exceptional that the processes appear to be an extension of the molding process. Spin welding is a rapid process that works well with large and small diameter parts, as well as a broad range of thermoplastic resins.

STANDARD FEATURES

- Micro-processor based system controls
- System part cycle counter
- Easy access gross head height adjustment
- Pressure regulator / filter
- Password protected machine setup menu
- Adjustable hydraulic speed control
- Fine pitch 24 tpi mechanical depth stop
- True system dwell time
- PID based temperature controllers with auto-tune feature
- In-temperature feature with out of temperature alarm
- 4" of available stroke
- Resettable day counter
- Quick tooling change over
- Lock out / tag out system dump
- Operating Manual
- Rigid tubular column design
- 1 year warranty



OPTIONS AVAILABLE

- Adjustable leveling base
- Automation remote actuation cables
- Pneumatic part clamping
- Standard rotary table with light curtain actuation
- Post Cooling
- Machine stand with casters
- Manual or pneumatic slide table
- Part presences detection hardware
- Optimus control/ package upgrade

MODEL .25 ACTUATOR SYSTEM

SPECIFICATIONS

- Nominal Pressure: 1/4 ton
- Clamp Pressure @ 100 psi: 500 lbs
- Cylinder Bore Dia. 2"
- Power Req.: 110vac or 208vac
- Pneumatic Req.: Clean, dry air at 100 psi 17 bar

DIMENSIONS

- Work base: (23.125 x 19.625 x 4 inches)
- Part height max: 13.00 inches
- Overall dimensions:
(19.625 W x 23.125 D x 38.875 H inches)
- Stroke: 4.00 inches
- Throat: 7.00 inches, from center of head
- Weight: 225 lbs.

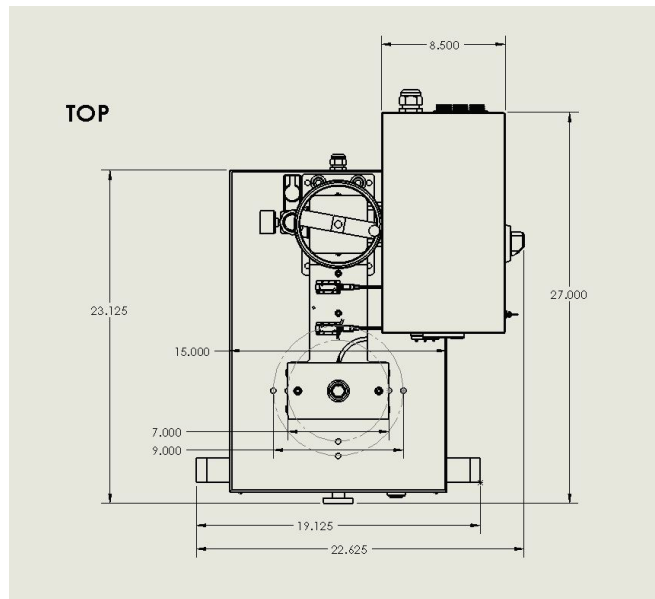
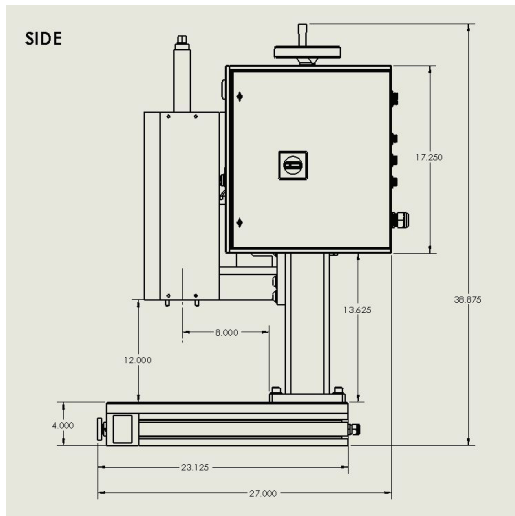
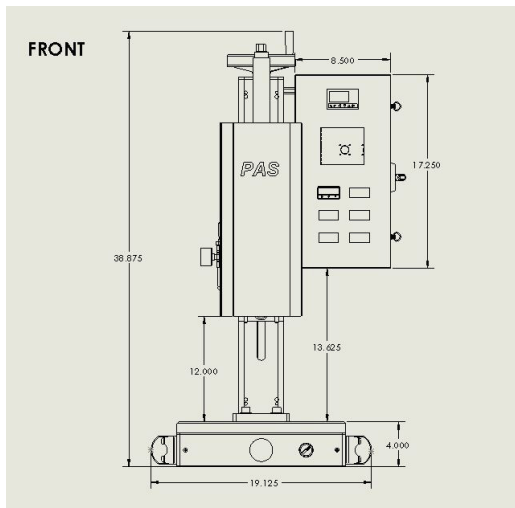
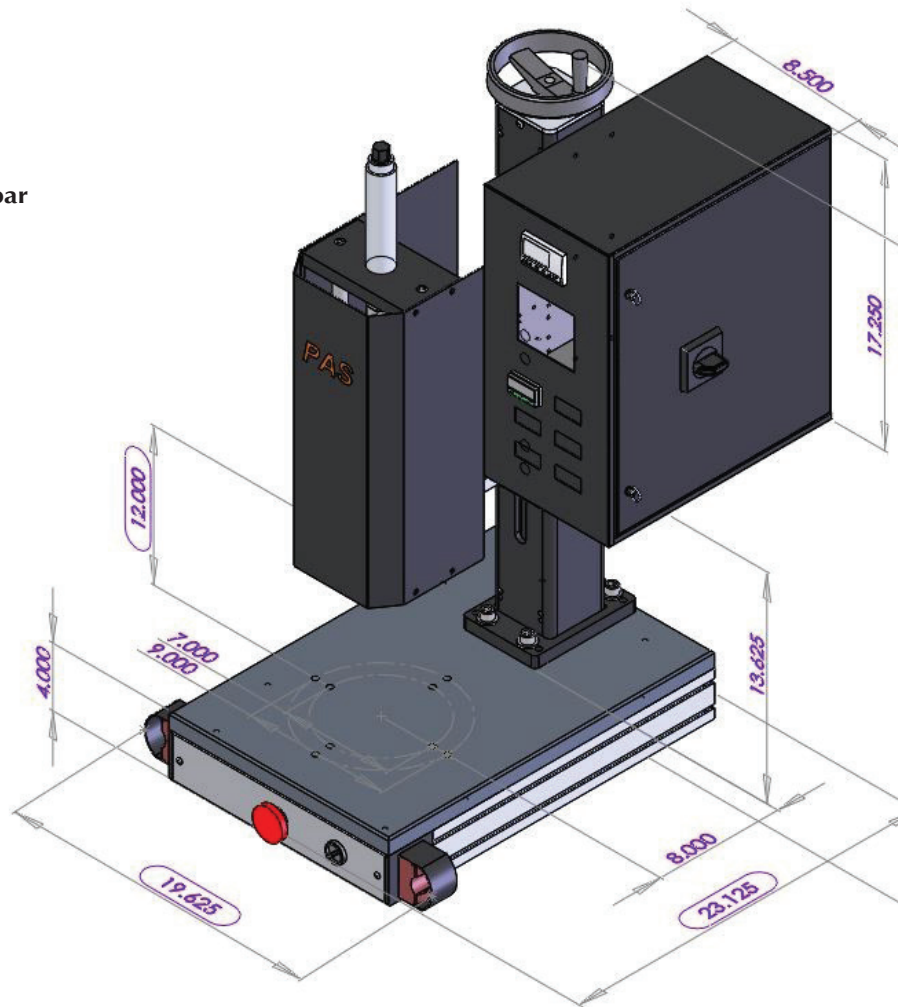

MODEL .25 ACTUATOR SYSTEM

SYSTEM CONTROLS

- Micro-processor based system.
- System parameters are easily entered in the panel mount PLC Display.
- In-temperature feature checks system prior to every cycle to assure proper operating temperature / operating window can be adjusted in 1 degree increments above and below temperature set point.
- True system dwell time.
- Password protected machine setup menu, allows only authorized operators to change the operating mode of the system.
- Multiple cycle counter, and re settable day counter.

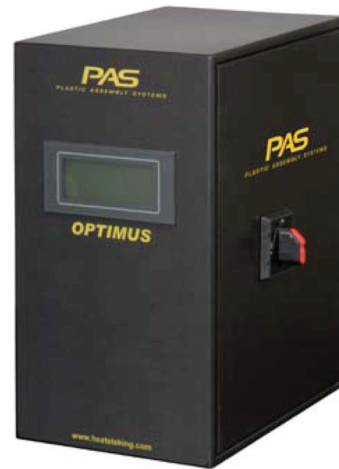

OPTIONAL
OPTIMUS
CONTROLS

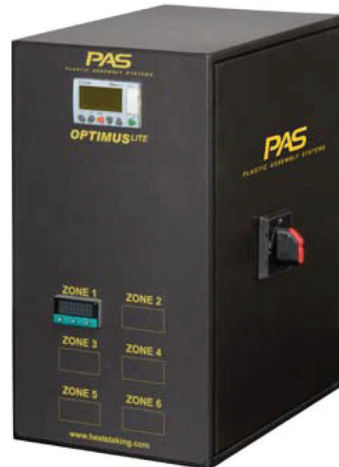

PANEL
MOUNT
PLC DISPLAY

