

MODEL .50AS ACTUATOR SYSTEM

PAS Model .50AS Actuator System is a low cost high quality heat staking machine designed for full production runs of small to medium sized parts.

Heatstaking, thermal insertion, swaging, de-gating, date-coding, sealing, and serializing all make use of direct contact heated tools. Also precisely controlled time, temperature, and pressure are used to reform plastic studs, walls, protrusions, and or to embed metal components into plastic. This offers the ability to perform multiple operations on several planes simultaneously. Cycle times are relatively quick, and productivity can be increase through the assembly of multiple products simultaneously. After the thermal process, cosmetics are so exceptional that the processes appear to be an extension of the molding process. Spin welding is a rapid process that works well with large and small diameter parts, as well as a broad range of thermoplastic resins.

STANDARD FEATURES

- Micro-processor based system controls
- System part cycle counter
- Internal PID based temperature controllers
- Easy access gross head height adjustment
- Pressure regulator
- 2 Year warranty
- Adjustable hydraulic speed control
- Fine pitch 24 tpi mechanical depth stop
- True system dwell time
- Password protected machine setup menu
- Multiple cycle counter, and re-settable day counter
- Internal multi-zone temperature control adjusted through touch screen (2) standard
- System cycle counter
- Post cooling
- 6" of available stroke
- Quick tooling change over
- Lock out tag out system dump
- Machine operating manual
- Dovetail column design
- TSD (Touch Screen Display)
- In-temperature feature

OPTIONS AVAILABLE

- Adjustable leveling base
- Automation remote actuation cables
- Manual part clamping
- Standard rotary tables with light curtain actuation
- Manual or pneumatic slide table
- Machine stand with casters
- Part presence detecting



MODEL .50AS ACTUATOR SYSTEM

SPECIFICATIONS

- Nominal Pressure: 112 ton
- Clamp Pressure @ 80 psi: 1000 lbs.
- Cylinder Bore Dia.: 4.00"
- Power Req. : 208 VAC, 1 phase , 20A
- Pneumatic Req. : Clean, dry air at 100 psi 17 bar

DIMENSIONS

- Work base: (22.25 x 15 x 4 inches)
- Part height max: 13.50 inches
- Overall dimensions:
(19.125 W x 22.25 D x 49.250 H inches)
- Stroke: 6.00 inches
- Throat: 7.00 inches, from center of head
- Weight: 250 lbs.

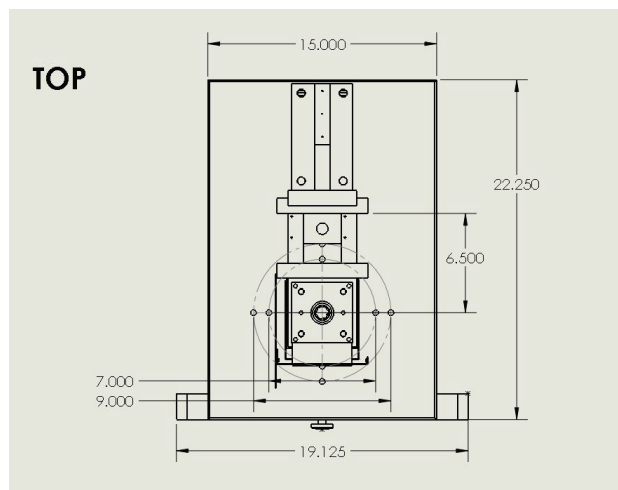
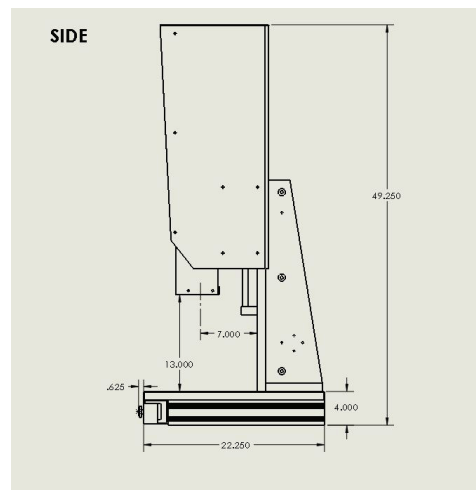
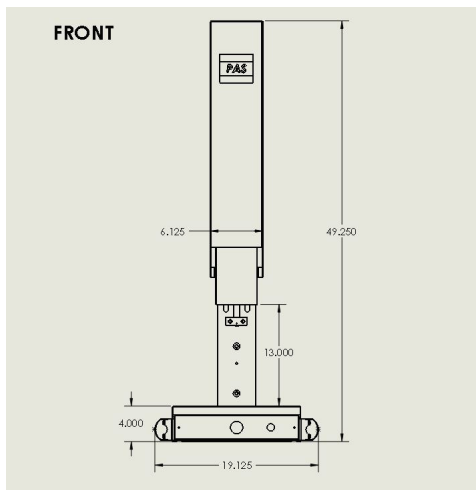
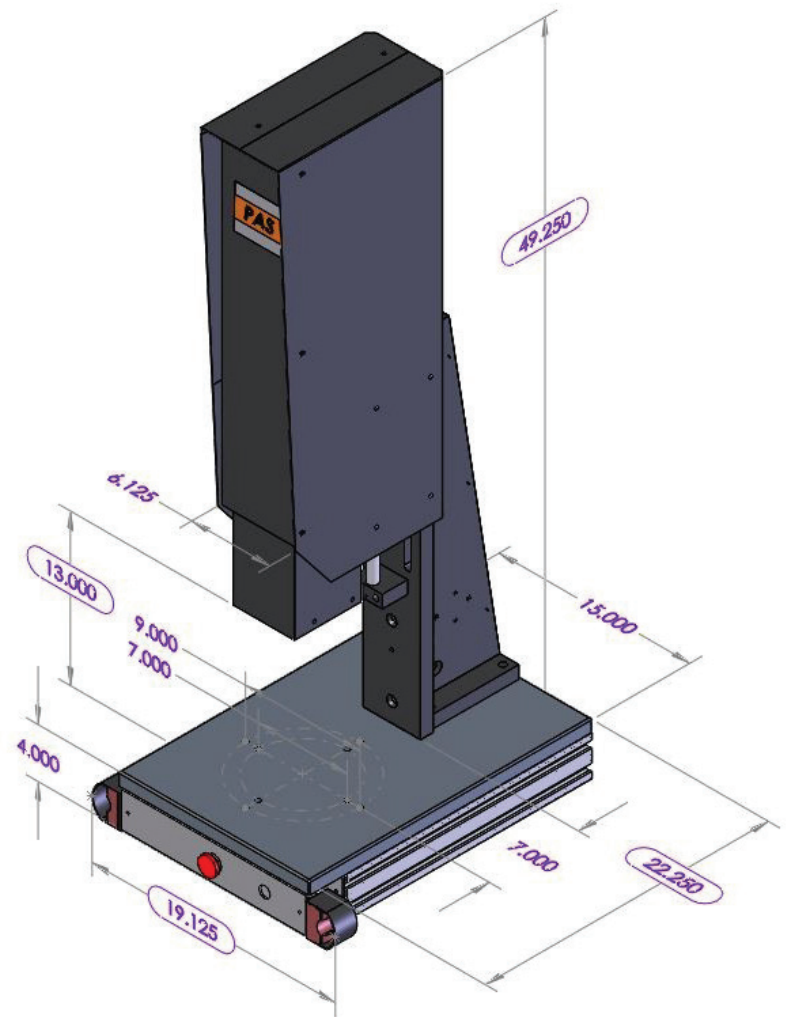

MODEL .50AS ACTUATOR SYSTEM

SYSTEM CONTROLS

- Micro-processor based system control offers large easy to read touch screen display
- Systems parameters are easily entered into the TSD through a large pop up menu numeric key pad
- In-temperature feature checks system prior to every cycle to assure proper operating temperature / operating window can be adjusted in 1 degree increments above and below temperature set point.
- True system dwell time and post cooling time destroy part memory and assures a tight assembly
- Password protected Machine setup menu, allows only authorized operators to change the operating mode of the system
- Post cooling, part presence detecting can be turned on or off by a simple press of a button
- Multiple cycle counter, and re-settable day counter
- Internal Multi-zone temperature control through touch screen capable up to four zones standard



TOUCH
SCREEN
INTERFACE



MULTIPLE
HEATER
OUTPUTS &
SYSTEM
OPERATION
CABLES

