

The most technologically advanced ultrasonic welding control features available today are found in PAS's **iQ Series** equipment. Our patented, 100% digitally controlled generator, ultra-rigid press, coupled with the **iQ Explorer** user-interface provide superior accuracy and ease of use. The generators have new multi-core processor technology that allows them to operate at a processing rate of 0.5 milliseconds. **iQ Explorer's** intuitive touch-screen graphical menu structure incorporates a one-page setup screen that makes welder operation easy to learn and program. Ethernet connectivity, wireless networking, and multiple USB ports are all options for weld and graph data storage. Over 25 programmable upper and lower process limits along with reference, weld graph logic are available for weld diagnostics and process consistency.

## SYSTEM FEATURES

- **The Generator Interface** incorporates a true color, 5" WVGA LCD screen, with 800 x 480 pixel resolution, and it is back lit by LEDs. **Menu navigation keys** are consistent with the entire **iQ** generator product line. Additionally **Quick program soft keys** border the screen and enhance intuitive menu navigation while maintaining the entire screen's usefulness.
- **Welder setup parameters** are all digitally controlled and can be calibrated to meet FDA and ISO requirements.
- **Multi-level password** options eliminate unauthorized changes to weld program, assuring part quality and consistency.
- **Weld by time, energy, distance, position, peak power and ground detect.**
- **15, 20, 30, 35, 40, 50 kHz** frequencies available.
- **180 W – 4800 W** versions, true RMS power.

## *iQ Series*

### ULTRASONIC PRESS SYSTEM

# ES



# IQ GENERATOR/POWER SUPPLY FEATURES

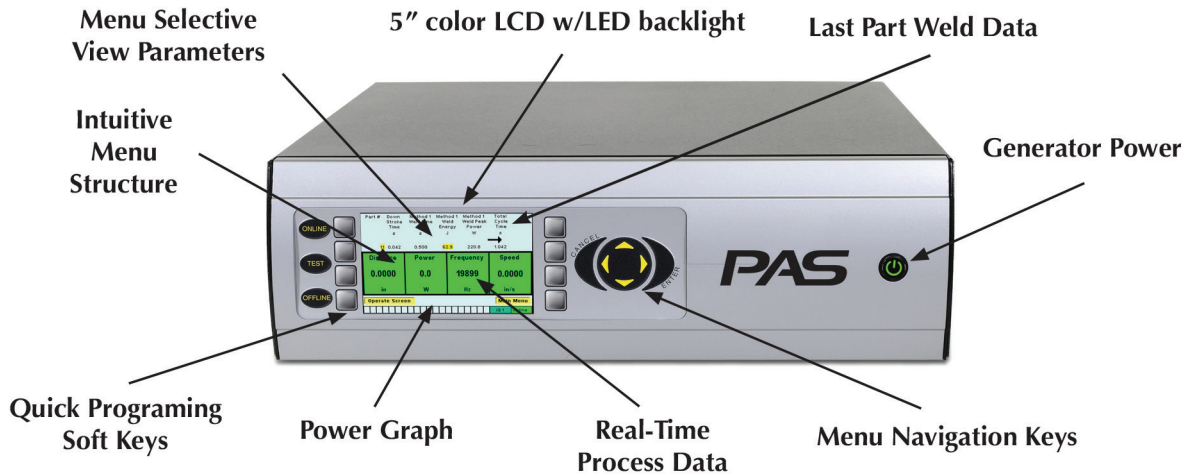

## Digital Features

- **100% digital control** of all power supply functions and parameters allows for unique configurations and future upgrades or requirements. Includes digital frequency synthesis.
- Industry leading data **acquisition rate speed of 0.5 ms** due to advanced **multi-core architecture**. Increased weld accuracy and repeatability.
- **Digi-Trac tuning** automatically tracks the resonant frequency digitally. Adjust the output frequency to match the acoustic stack (sonotrode, booster, and transducer) for every weld cycle and eliminate the need to manually tune the generator.
- **Ultrasonic overload protection**, with status indicator for ease of troubleshooting. The overload power limit is based on true RMS power output level.
- **Line voltage regulation** compensates for line fluctuations assuring consistent amplitude.
- **Temperature drift compensation** allows for seamless acoustic stack operation, and automatically compensates for acoustic stack temperature changes.
- **Patented Pulse-Width Modulation** design delivers power more efficiently with substantially less stress on the electrical and acoustic components for superior performance, reliability and extended life.
- **Linear ramp soft-start** algorithm allows the acoustic stack to be brought to operating amplitude smoothly, minimizing start-up surges and abnormal stress to the stack and power supply.
- **Load regulation** provides constant ultrasound amplitude automatically regardless of the power draw. The ultrasonic output amplitude level is held to within 1%, to provide weld process consistency and reduced weld cycle times.

## Mechanical Features

- **Flow through cooling** tunnel with a matched high performance heat sink and thermostatically controlled fan reduces thermal gradients, minimizes dirt infiltration and increases component life.



- **Highest power density** per unit of volume. Most power in the smallest package at highest duty cycle. Low and high profile configurations available.
- **RS232 serial configuration port** is used for field software upgrades, troubleshooting and advanced hardware setup with optional PC based iQ configurator.
- **Advanced I/O is standard** with 25-pin output, and 15-pin input, user configurable from the utility menu.
- Unique **patented modular hardware design** incorporates motherboard/interconnect of internal components. Reduces internal cabling while increasing reliability and performance.
- **Rear panel expansion** slot is available to allow for custom configurations for OEM and cost effective designed solutions.

# IQ GENERATOR/POWER SUPPLY FEATURES

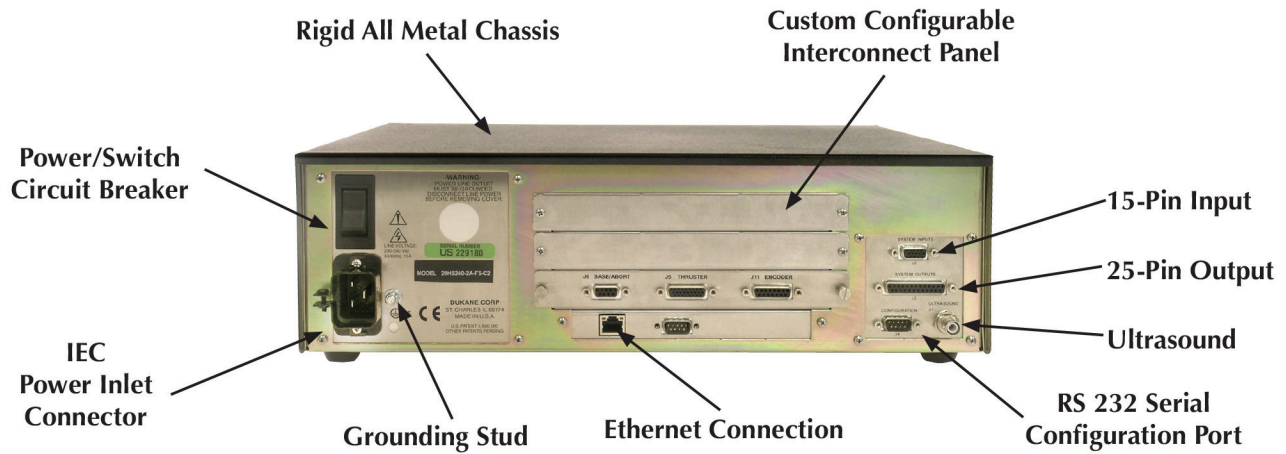

## Features

- **Compact, single-rail linear ball slide assembly** system offers accurate positioning, stable movement, and friction-free travel.
- **Dual pressure** increases clamp force to improve melt during the weld cycle, or to provide tighter assembly during the hold cycle.
- **7" (178 mm) stroke** with mechanical bottom stop adjustable in .001" (.025 mm) increments.
- **Top-of-stroke limit switch** for automation application
- **All controls are accessible from the front** for convenient set-up and operation.
- **Easy-to-use front panel position indicators** with universal icons instantly show settings of position and bottom stop, and optional slow speed, pre-trigger, and end-of weld switches.
- **Titanium boosters** are standard.
- **Internally mounted optional linear encoder** saves space in multihead and automated installations.
- **OSHA-required lockout for air supply** is standard.
- **Ergonomic base and opto-touch cycle activation switches** reduce operator fatigue.
- **Status indicators in base** for Power, In Cycle, and Abort clearly communicate system conditions.
- Twist-release **emergency stop switch** meets international safety standards.
- **Press/thruster design provides system flexibility and upgradeability**, reducing equipment investment.

## Options

- **Ultra-Rigid** support provides reduced deflection for superior weld consistency. Column crank and gas strut assist ensures easy setup. Column can be locked to eliminate unauthorized adjustments. Standard style support columns available.
- **Programmable pressure profiling** and force by interface with the electronic pressure regulator, pressure transducer, and load cell press options offer increased control, repeatability and consistency.
- **iQ-HMI industrial PC 15" TFT XGA LCD** touch screen, Supports four USB 2.0 ports, Dual Gigabit Ethernet.
- **iQ-Explorer II** intuitive Windows based graphical user interface.
- **Hydraulic speed control** offers precision hydraulic control of the melt velocity. This is critical to achieve maximum weld strength in staking, inserting and shear joint applications.
- **Resonant mount booster.**
- **Longer press columns** to increase part load area height.
- **Custom air cylinder** 1.50" (38 mm), or 2.00" (51 mm and 3.00" (76 mm) diameters.
- **19" (483 mm) Rack or Press-mounted** generator option applications.



Color front panel generator.

# SPECIFICATIONS



15-20 kHz  
High Power  
Press System  
w/ultra Rigid  
Support



Standard  
20-30-40 kHz  
Press System  
w/ultra Rigid  
support



Standard  
20-30-40-50 kHz  
Mini Press  
System

## iQ Power Supply

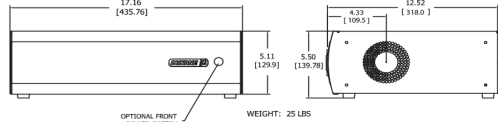

## Optional iQ HMI

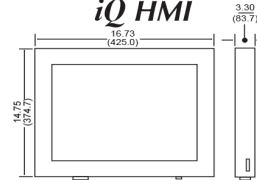

### System Requirements

Pneumatic requirements: 80-110 psi max. clean, dry air

Allow 5.00" (130mm) behind the press/thruster for air line and cable connections



ES Generator

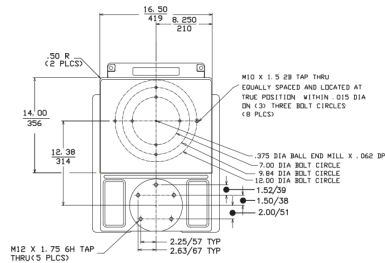

Typical 20 kHz system listed.

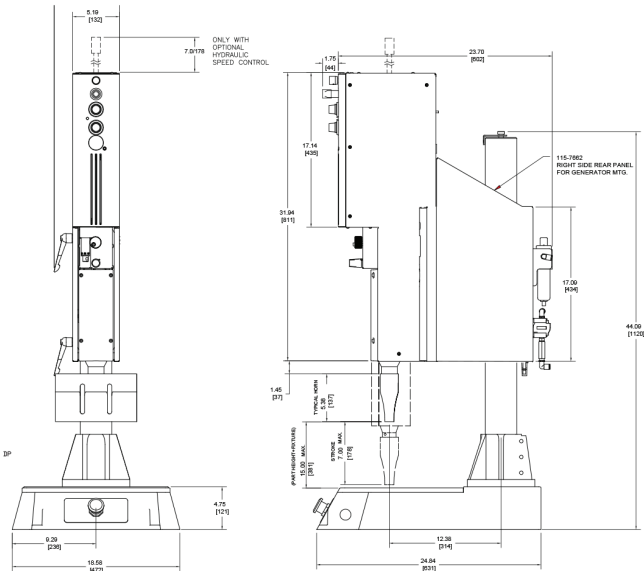

20 kHz Standard Support

# DIMENSIONS

Press Dimensions	Standard	Ultra Rigid	Thruster Dimensions	
Base Width	18.58" (472 mm)	18.58" (472 mm)	Housing Height	31.94" (811 mm)
Base Depth	24.84" (631 mm)	24.83" (631 mm)	Housing Width	5.19" (132 mm)
Column Height	39.00" (991 mm)	40.00" (1002 mm)	Housing Depth	11.00" (280 mm) Max.
Column Profile	3.50" (89 mm) Ø	6.0" x 3.0" (152 mm x 76 mm)	Weight	40.00 lb (18 kg)
Maximum Height	57.00" (1450 mm)	61.00" (1550 mm)		
Housing Width	5.19" (132 mm)	5.19" (132 mm)	iQ HMI Dimensions	
Column CL to Horn CL	12.38" (314 mm)	12.38" (314 mm)	Height	13" (330 mm)
Useable Throat	8.00" (200 mm)	8.38" (212 mm)	Width	17.13" (435 mm)
Stroke	7.00" (178 mm)	7.00" (178 mm)	Depth	3.07" (78 mm)
Weight	170.00 lb (77 kg)	240.00 lb (109 kg)	LCD Diagonal	15" (381 mm)

# MODELS

Power /Frequency	600 W	900 W	1200 W	1800 W	2400 W	3600 W	4800 W
15 kHz						X	X
20 kHz		X	X	X	X	X	X
30 kHz	X	X	X	X			
35 kHz			X				
40 kHz	X	X	X				
AC Line Max. Current:	10 amps	10 amps	15 amps	15 amps	15 amps	30 amps	30 amps

